

COPYRIGHT © Hangzhou EZVIZ Software Co., Ltd. ALL RIGHTS RESERVED.

Any and all information, including, among others, wordings, pictures, graphs are the properties of Hangzhou EZVIZ Software Co., Ltd. (hereinafter referred to as "EZVIZ"). This user manual (hereinafter referred to as "the Manual") cannot be reproduced, changed, translated, or distributed, partially or wholly, by any means, without the prior written permission of EZVIZ. Unless otherwise stipulated, EZVIZ does not make any warranties, guarantees or representations, express or implied, regarding to the Manual.

About this Manual

The Manual includes instructions for using and managing the product. Pictures, charts, images and all other information hereinafter are for description and explanation only. The information contained in the Manual is subject to change, without notice, due to firmware updates or other reasons. Please find the latest version in the EZVIZ™ website (<http://www.ezviz.com>).

Revision Record

New release – January, 2026

Trademarks Acknowledgement

EZVIZ™, ™ and other EZVIZ's trademarks and logos are the properties of EZVIZ in various jurisdictions. Apple and the Apple logo are trademarks of Apple Inc., registered in the U.S. and other countries. App Store is a service mark of Apple Inc., registered in the U.S. and other countries. Google Play and the Google Play logo are trademarks of Google LLC. Other trademarks and logos mentioned below are the properties of their respective owners.

Legal Disclaimer

TO THE MAXIMUM EXTENT PERMITTED BY APPLICABLE LAW, THE PRODUCT DESCRIBED, WITH ITS HARDWARE, SOFTWARE AND FIRMWARE, IS PROVIDED "AS IS", WITH ALL FAULTS AND ERRORS, AND EZVIZ MAKES NO WARRANTIES, EXPRESS OR IMPLIED, INCLUDING WITHOUT LIMITATION, MERCHANTABILITY, SATISFACTORY QUALITY, FITNESS FOR A PARTICULAR PURPOSE, AND NON-INFRINGEMENT OF THIRD PARTY. IN NO EVENT WILL EZVIZ, ITS DIRECTORS, OFFICERS, EMPLOYEES, OR AGENTS BE LIABLE TO YOU FOR ANY SPECIAL, CONSEQUENTIAL, INCIDENTAL, OR INDIRECT DAMAGES, INCLUDING, AMONG OTHERS, DAMAGES FOR LOSS OF BUSINESS PROFITS, BUSINESS INTERRUPTION, OR LOSS OF DATA OR DOCUMENTATION, IN CONNECTION WITH THE USE OF THIS PRODUCT, EVEN IF EZVIZ HAS BEEN ADVISED OF THE POSSIBILITY OF SUCH DAMAGES.

TO THE MAXIMUM EXTENT PERMITTED BY APPLICABLE LAW, IN NO EVENT SHALL EZVIZ'S TOTAL LIABILITY FOR ALL DAMAGES EXCEED THE ORIGINAL PURCHASE PRICE OF THE PRODUCT.

EZVIZ DOES NOT UNDERTAKE ANY LIABILITY FOR PERSONAL INJURY OR PROPERTY DAMAGE AS THE RESULT OF PRODUCT INTERRUPTION OR SERVICE TERMINATION CAUSED BY: A) IMPROPER INSTALLATION OR USAGE OTHER THAN AS REQUESTED; B) THE PROTECTION OF NATIONAL OR PUBLIC INTERESTS; C) FORCE MAJEURE; D) YOURSELF OR THE THIRD PARTY, INCLUDING WITHOUT LIMITATION, USING ANY THIRD PARTY'S PRODUCTS, SOFTWARE, APPLICATIONS, AND AMONG OTHERS.

REGARDING TO THE PRODUCT WITH INTERNET ACCESS, THE USE OF PRODUCT SHALL BE WHOLLY AT YOUR OWN RISKS. EZVIZ SHALL NOT TAKE ANY RESPONSIBILITIES FOR ABNORMAL OPERATION, PRIVACY LEAKAGE OR OTHER DAMAGES RESULTING FROM CYBER ATTACK, HACKER ATTACK, VIRUS INSPECTION, OR OTHER INTERNET SECURITY RISKS; HOWEVER, EZVIZ WILL PROVIDE TIMELY TECHNICAL SUPPORT IF REQUIRED. SURVEILLANCE LAWS AND DATA PROTECTION LAWS VARY BY JURISDICTION. PLEASE CHECK ALL RELEVANT LAWS IN YOUR JURISDICTION BEFORE USING THIS PRODUCT IN ORDER TO ENSURE THAT YOUR USE CONFORMS TO THE APPLICABLE LAW. EZVIZ SHALL NOT BE LIABLE IN THE EVENT THAT THIS PRODUCT IS USED WITH ILLEGITIMATE PURPOSES.

IN THE EVENT OF ANY CONFLICTS BETWEEN THE ABOVE AND THE APPLICABLE LAW, THE LATTER PREVAILS.

Table of Contents

Overview	1
1. Package Contents	1
2. Basics	2
Quick Start Guide	6
1. Install Dirt Collection Tray and Ramp	6
2. Choose Installation Location	7
3. Connect Water Pipes (Mopping version only)	8
4. Add Cleaning Solution (Mopping version only)	9
5. Connect the Base Station to the Power Supply	9
6. Pair the Base Station with Robot	10
7. Install Nano SIM Card (Optional)	10
Download EZVIZ Robotics App	11
Add Device to EZVIZ Robotics	12
Basic Operation	13
Operations on the EZVIZ Robotics App	14
Routine Maintenance	14
1. Clean Base Station	15
2. Preparation for Cleaning Robot	16
3. Clean Main Brush	16
4. Clean Dirty Water Tank (Mopping version only)	18
5. Clean Important Components	20
6. Replace Dust Bag (Vacuum version only)	21
7. Recall Robot to Base Station	21
FAQ	23
Environmental Precautions	24
Initiatives on the Use of Video Products	25

Overview

1. Package Contents

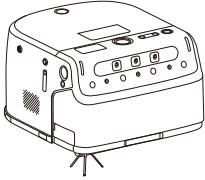

Robot (x1)

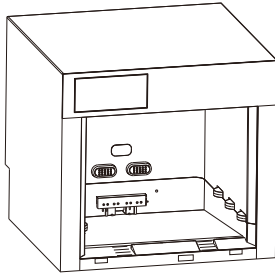

Base Station (x1)



Ramp (x1)



Dirt Collection Tray (x1)

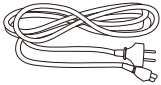

Power Cable (x1)



Side Brush (x1)



Cleaning Tool (x1)



Quick Start Guide (x3)



Regulatory Information (x1)

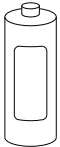

Cleaning Solution (x1)
(Mopping version only)

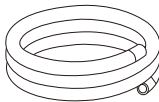

Drain Pipe (x1)
(Mopping version only)

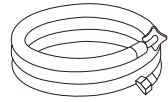

Water Supply Pipe (x1)
(Mopping version only)



Three-way Valve (x1)
(Mopping version only)

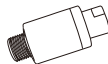

Pressure Relief Valve (x1)
(Mopping version only)

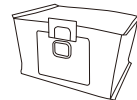



Dust Bag (x1)
(Vacuum version only)

2. Basics

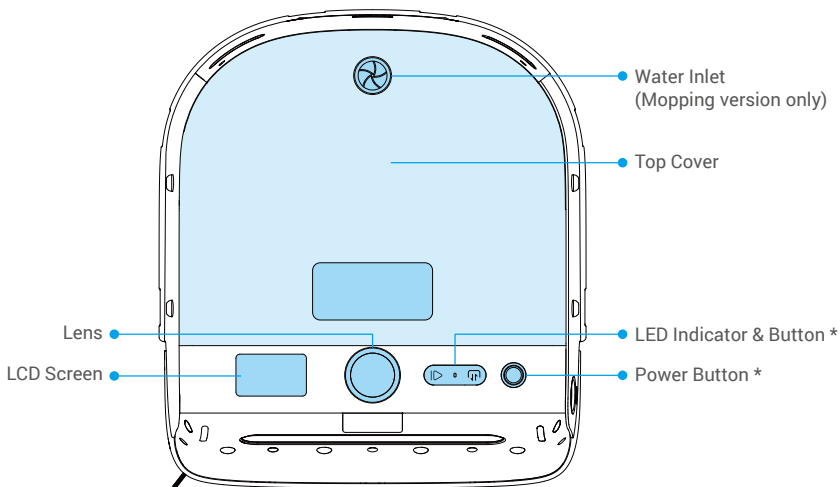
Robot







Button

	Start/Pause	<ul style="list-style-type: none"> • Press once: Start/pause task • Press and hold for 5 seconds: Robot ready for network configuration
	Exit/Recall	<ul style="list-style-type: none"> • Press once: Robot exit/return base station • Press and hold for 5 seconds: Robot ready for pairing
	Press and hold for 5 seconds:	Restore to factory settings

Power Button

Press once: Turn on/off the robot

LED Indicator

	Solid blue	Working properly
	Fast-flashing blue	Robot in network configuration
	Slow-flashing blue	Robot and base station pairing in progress
	Fast-flashing red	Fault or exception
	Slow-flashing red	No network connection

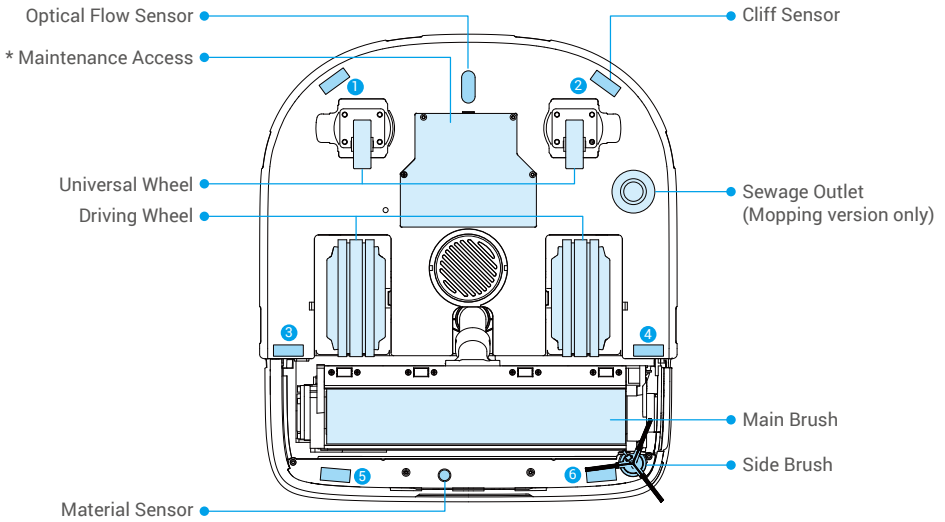

Maintenance Access

Authorized personnel only. Unauthorized access may cause device damage. In case of malfunction, please contact after-sales service.

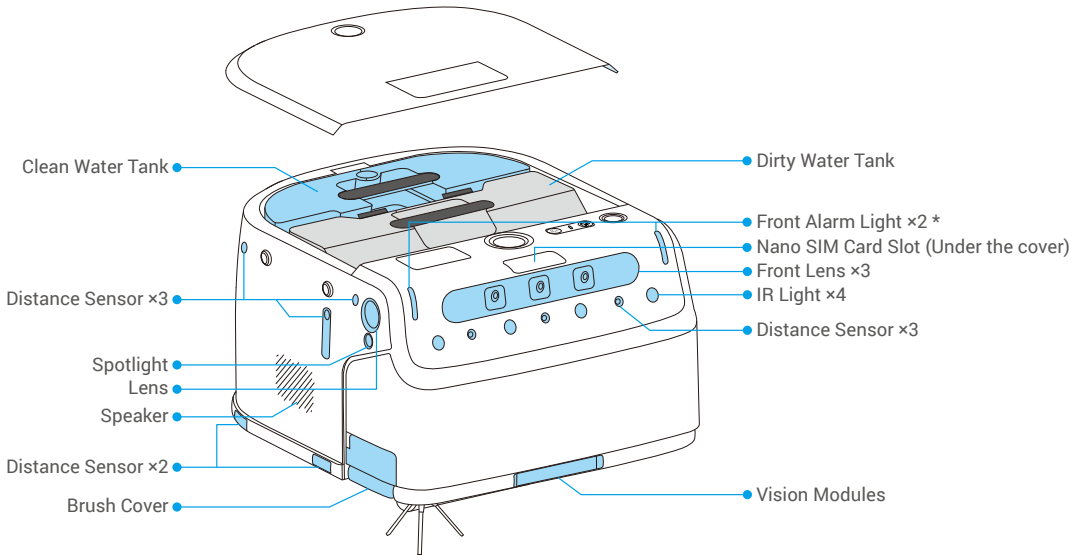

Mopping Version

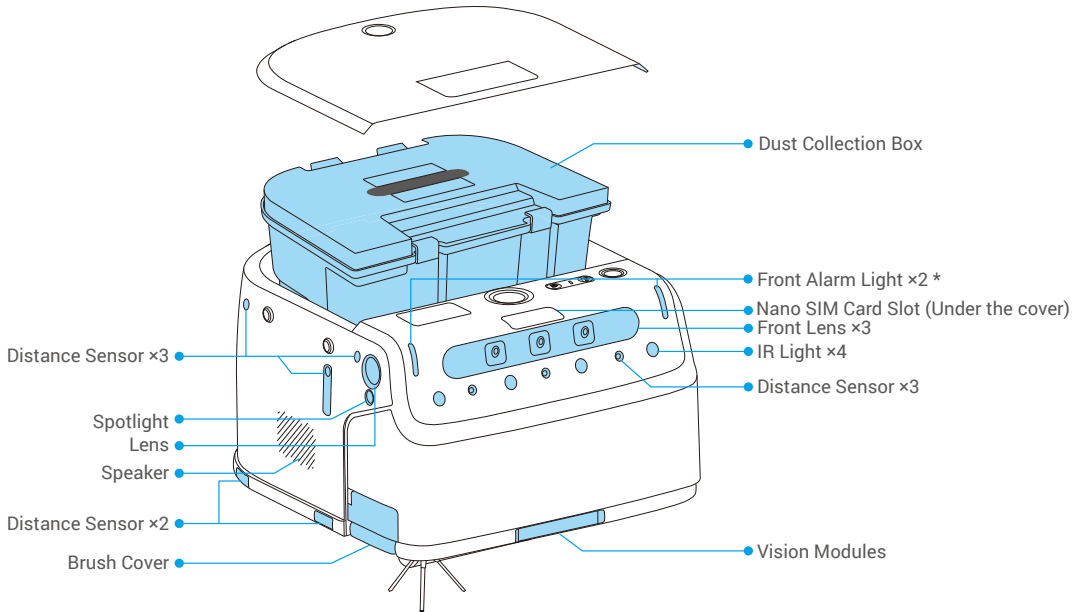

Vacuum Version

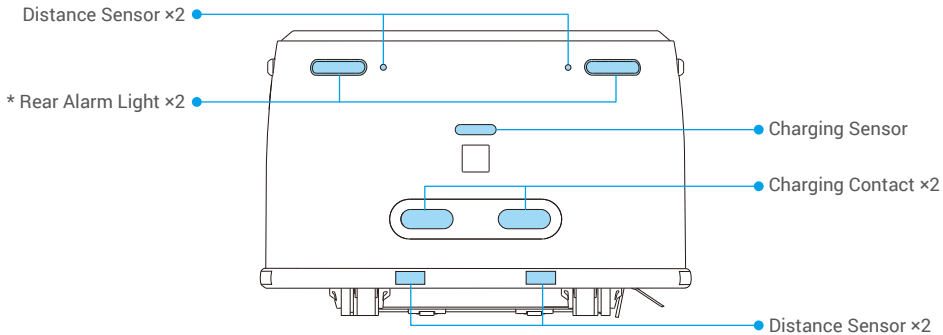



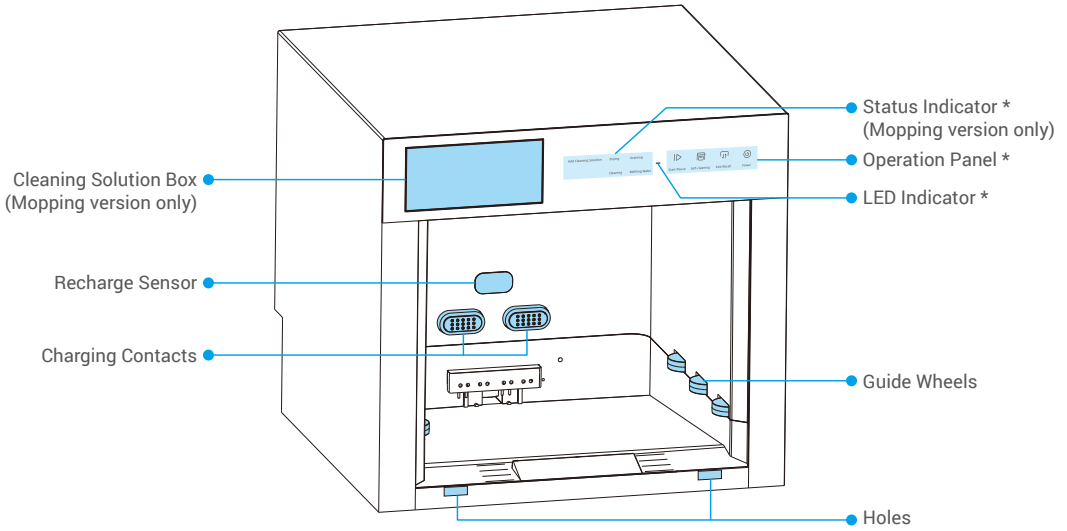

Front/Rear Alarm Light

●●●● Flashing orange Robot is working

Base Station







Operation Panel

	Start/Pause	<ul style="list-style-type: none"> • Press once: Start/pause task • Press and hold for 3 seconds: Enable/disable child lock
	Self-cleaning	<ul style="list-style-type: none"> • Robot inside the base station: Press once to start robot self-cleaning • Robot outside the base station: Press once to start base station self-cleaning
	Exit/Recall	<ul style="list-style-type: none"> • Press once: Robot exit/return base station • Press and hold for 3 seconds: Base station ready for pairing
	Power	<ul style="list-style-type: none"> • Press once: Turn on the robot • Press and hold for 3 seconds: Turn off the robot

Status Indicator

- Text stays lit: Function is in progress
- Text flashes: Function fault or exception
- All text + icons flash: Child lock enabled

LED Indicator

	Solid blue	Working properly
	Fast-flashing blue	Base station in network configuration
	Fast-flashing red	Fault or exception
	Slow-flashing red	No network connection

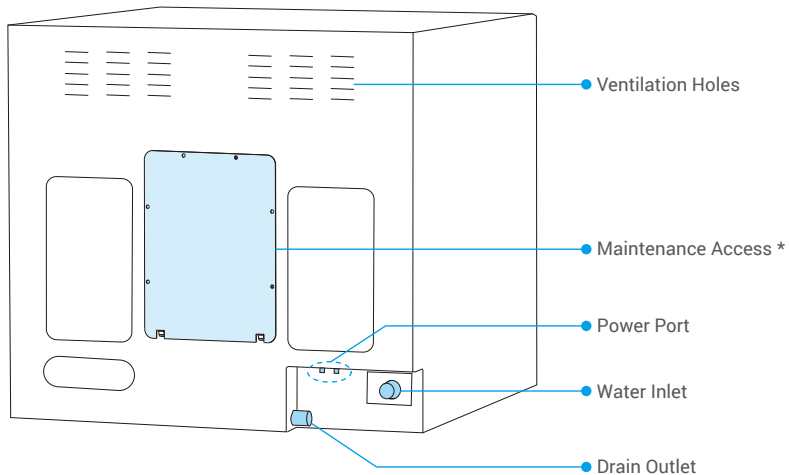

Maintenance Access

Authorized personnel only. Unauthorized access may cause device damage. In case of malfunction, please contact after-sales service.

Quick Start Guide

1. Install Dirt Collection Tray and Ramp

1. Put the dirt collection tray in the base station with its notch facing inward.

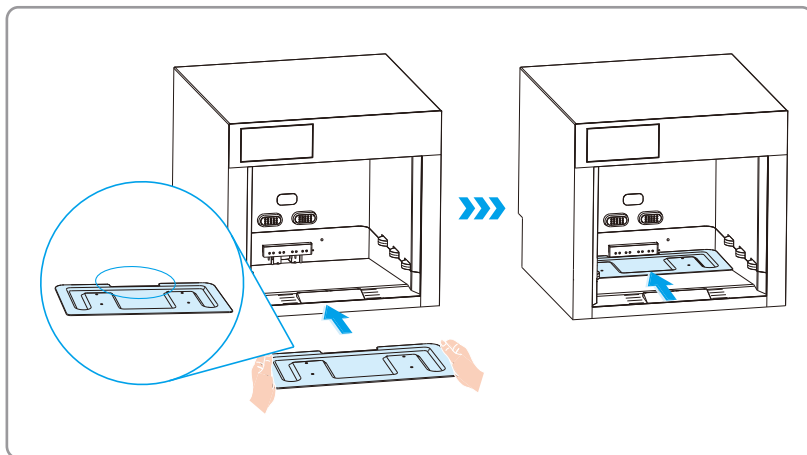

2. Align the clips of the ramp with the holes on the base station and install it, ensuring it is securely fastened.

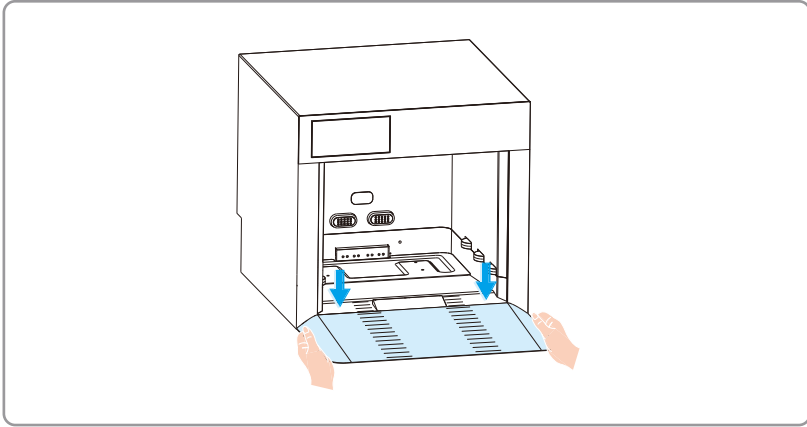

2. Choose Installation Location

- i** Ensure the installation location has a nearby power outlet and, for the mopping version, a water supply valve and drain. Keep the base station's power port and water inlets/outlets unobstructed.

Place against the wall: Place the base station on a level surface against a wall, leaving at least 2 cm of space behind it.

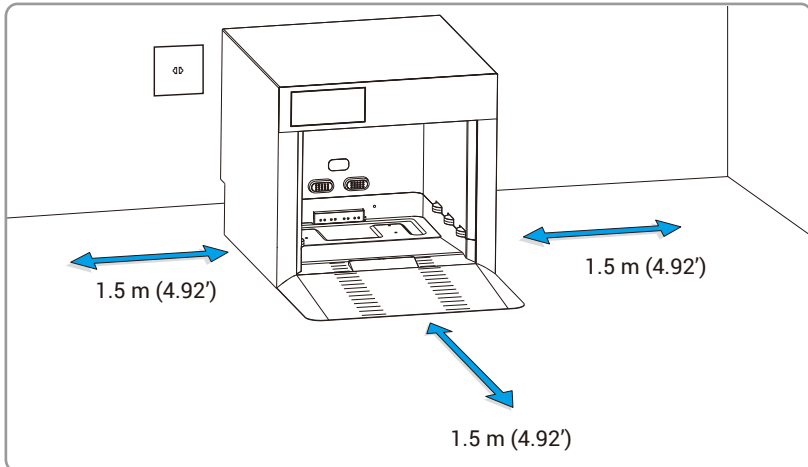

Embedded installation: Place the base station securely into a reserved space of suitable dimensions.

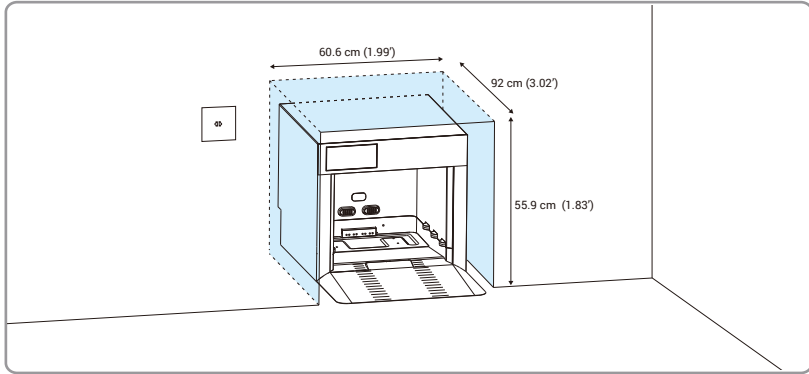

3. Connect Water Pipes (Mopping version only)

Connect one end of the water supply pipe to the water inlet of the base station and the other end to water source. Connect one end of the drain pipe to the drain outlet of the base station and place the other end into a drain.

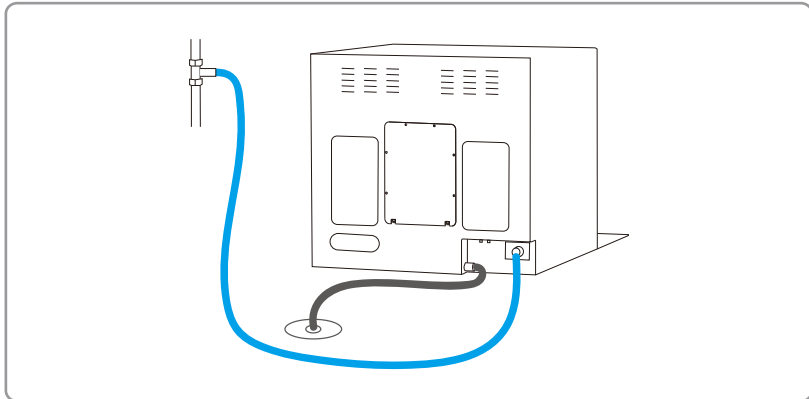

4. Add Cleaning Solution (Mopping version only)

Press to open the cleaning solution box and add cleaning solution.

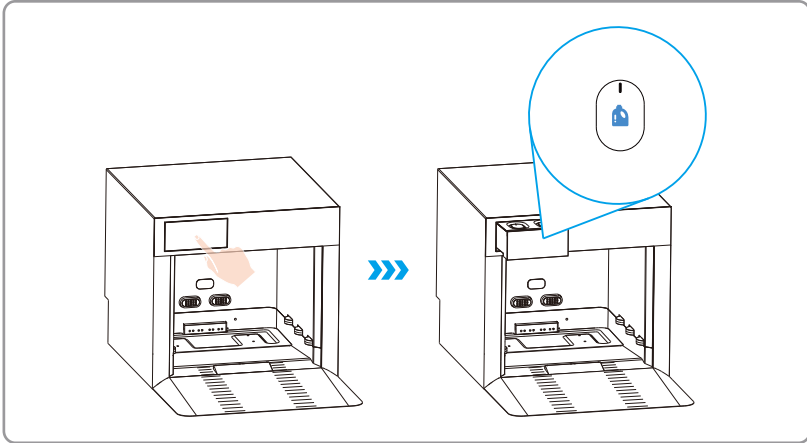

5. Connect the Base Station to the Power Supply

Take out the power cable included in the package and connect the base station to the power outlet.

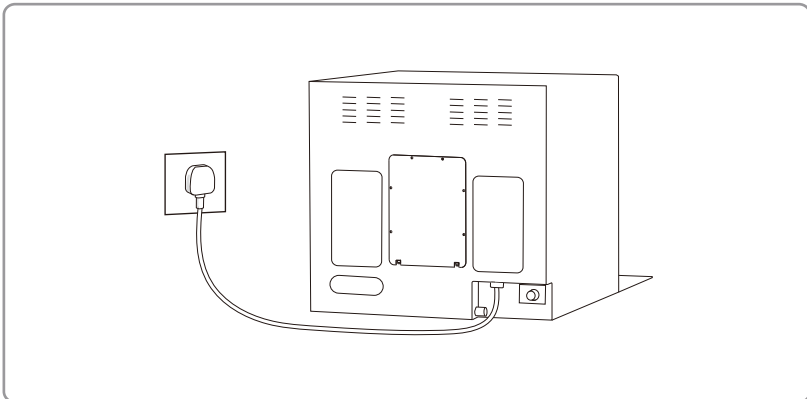

6. Pair the Base Station with Robot

1. Press power button on the robot to turn it on.
2. Swipe down on the robot's LCD screen and tap "Base Station".
3. Press and hold the  button on the base station for 3 seconds, then follow the screen prompts. When "Base station connected" appears on the screen, pairing is complete.

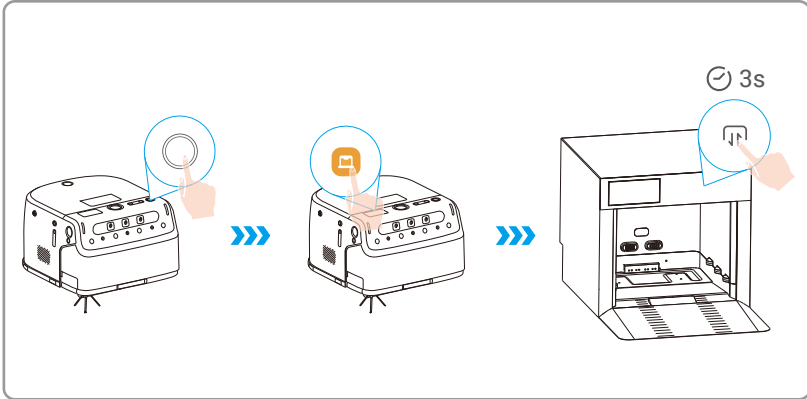

4. After pairing is complete, press the  button on the operation panel. The robot will enter the base station and start charging.

7. Install Nano SIM Card (Optional)

What is a Nano SIM card?

Nano SIM cards measure 12.3 mm × 8.8 mm × 0.67 mm, making them the smallest of the three types.

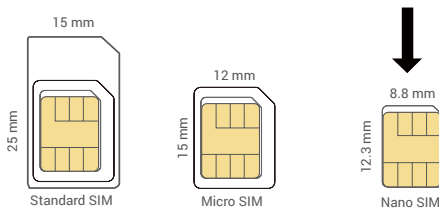

When the SIM card PIN is locked, it needs to be unlocked before being insert into the device.

How to unlock the SIM PIN of my Nano SIM card?

Most SIM PINs can be set up to unlock on your phone, as follows:

- For iOS system:
 1. Insert your Nano SIM card.
 2. On your phone, go to Settings -> Cellular -> SIMs -> SIM PIN.
 3. Under SIM PIN, touch to disable the SIM PIN by entering PIN code.

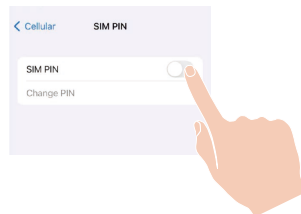

- For Android system:
 1. Insert your Nano SIM card.
 2. On your phone, go to Settings -> Security -> More Settings -> SIM PIN.
 3. Under SIM PIN, touch to disable the SIM PIN by entering PIN code.

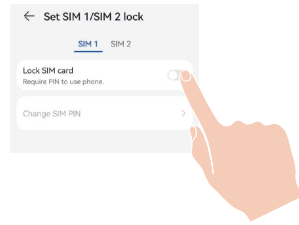

If the SIM PIN cannot be unlocked or is invalid, please contact your carrier.

Insert a 4G Nano SIM card (purchase separately) into the Nano SIM card slot as shown in the figure below.

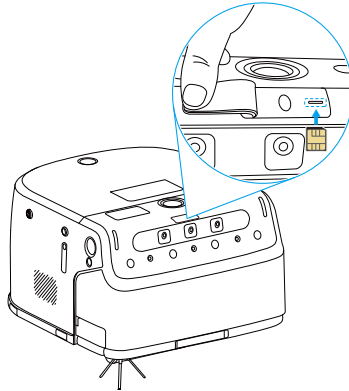

Download EZVIZ Robotics App

1. Connect your mobile phone to 2.4GHz Wi-Fi (suggested).
2. Download and install the EZVIZ Robotics app by searching for "EZVIZ Robotics" in the App Store or Google Play™.
3. Launch the app and register an EZVIZ Robotics user account.

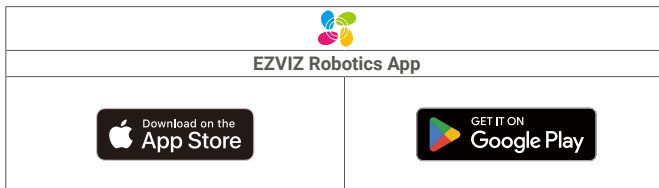

- i** If you have already used the app, please make sure that it is the latest version. To find out if an update is available, go to the app store and search for EZVIZ Robotics.

Add Device to EZVIZ Robotics

1. Press  button on the base station. The robot will exit the base station.
2. Log in to your EZVIZ Robotics app account, tap "Dashboard -> Add Device" to go to the Scan QR Code page.
3. Swipe down from the robot's LCD screen, then tap "Wi-Fi -> Scan the QR code to configure network", then scan the QR code displayed on the screen.
4. Follow the EZVIZ Robotics app wizard to add the robot to your EZVIZ Robotics account.

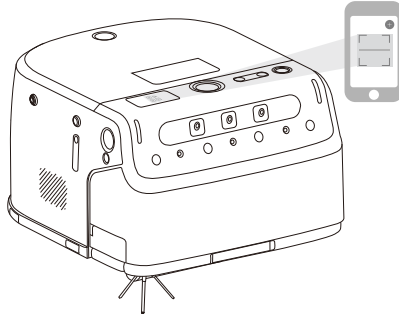



Basic Operation

- For the first time use, it is recommended to fully charge the robot and ensure it is placed inside the base station.
- Avoid placing reflective materials (e.g., glass, mirrors) near the base station.
- The robot will map the area and start cleaning task.
- Keep the area 1.5 meters in front of the base station clear to avoid mapping issues.

Start working in one of the following three ways:

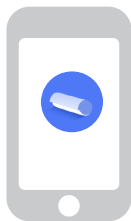
- Log in to your EZVIZ Robotics app and tap .



- Press  button on the base station. The robot will exit the base station and start mapping.

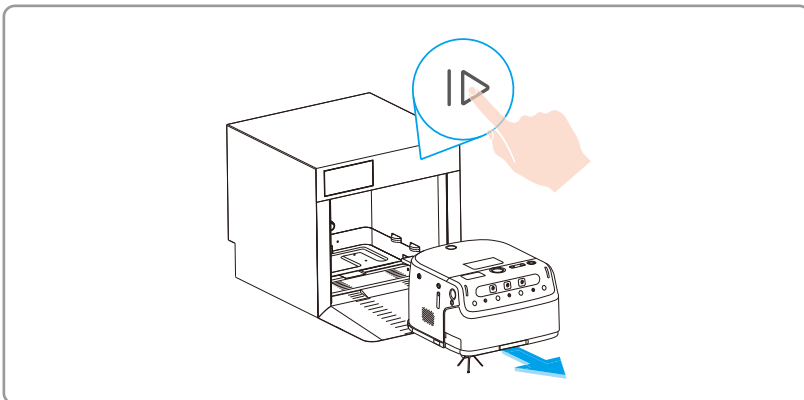

- Press  button on the robot. The robot will exit the base station and start mapping.

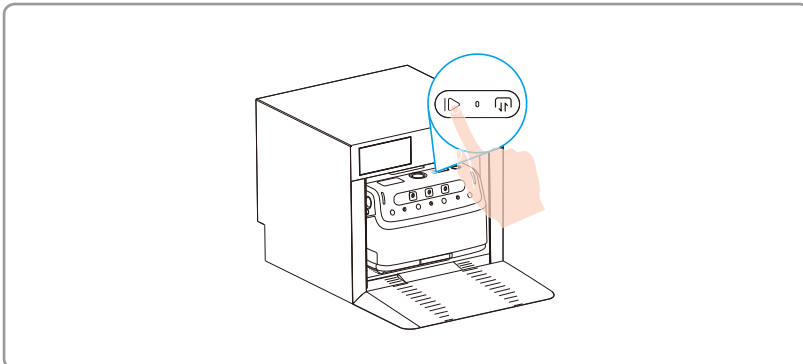

Operations on the EZVIZ Robotics App

i The app interface may change due to version update.

Dashboard

Displays cleaning progress, cleaning duration, robot grouping status, important messages, and consumables & maintenance information.

Device

Check device status, select cleaning mode, set cleaning preferences, and start cleaning tasks.

Cleaning Mode

Includes standard mopping, cleaning solution mopping and silent dust pushing.

Area Cleaning

You can customize and save specific cleaning areas, then select area for targeted cleaning.

Cleaning Preferences

You can customize cleaning settings based on personal needs, including the following options: cleaning solution concentration, cleaning intensity, suction power, roller brush speed, water volume, and more.

Inspection

Supports live view, video playback, remote control, point navigation, and preset point navigation.

Message

Displays key information including important messages, operational messages, security messages, and device maintenance information.

Routine Maintenance

- i** • Before performing cleaning and maintenance tasks on the robot, turn the robot off and unplug the base station.
- EZVIZ manufactures various replacement parts and fittings. Please visit www.ezviz.com for more information on replacement parts.
- Accessories are considered consumables and regular maintenance and replacement are recommended. Due to their wear characteristics, they are not subject to the standard product warranty period.

To maintain the best condition of the device, please maintain the device and replace parts with following frequencies:

Part	Lifespan/Maintenance Frequency
Side Brush	150 hours
Main Brush	400 hours
Rubber Strip	700 hours
HEPA	500 hours
Lens/Distance Sensor/Supplement Light/IR Light/Vision Modules/Material Sensor/Optical Flow Sensor/Cliff Sensor/Charging Sensor/Charging Contact/Universal Wheel/Driving Wheel	Once per week
Clean Water Tank	After each mopping
Dirty Water Tank	After each mopping
Base Station	Every 2 weeks

1. Clean Base Station

i Keep the front of the base station clear of obstacles. Remove large debris from inside the base station first.

1. Press  and the robot exits the base station.

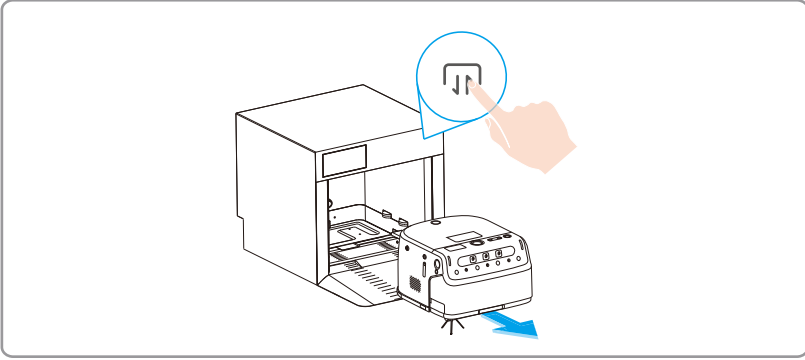

2. Press , when the base station sprays water at the bottom, take out the waste tray and clean the interior with a cleaning tool.

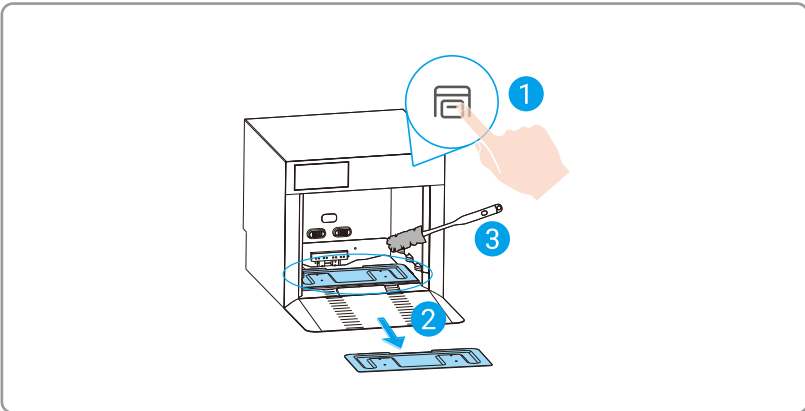

2. Preparation for Cleaning Robot

1. Remove the robot's top cover.
2. Take out the water tanks/dust collection box.
3. Place the robot on its side (do not invert it), press down on the brush cover, then open it.

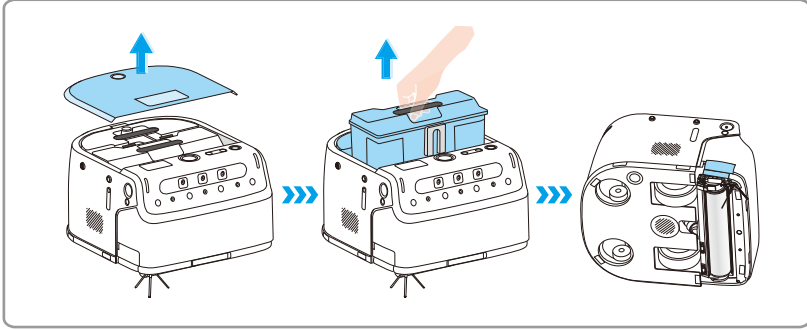

3. Clean Main Brush

1. Use your finger to push the spring pin to unlock the main brush.
2. Rotate the brush knob counterclockwise to unlock the main brush and take it out.

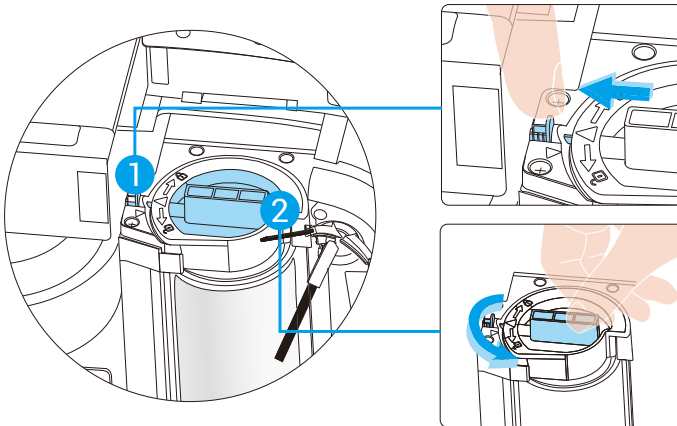

3. Use a cleaning tool to remove hair and debris from the main brush, roller cavity, air duct, dirt inlet, and water outlet. Clean the wiper strip with the tool and dry it with a cloth.

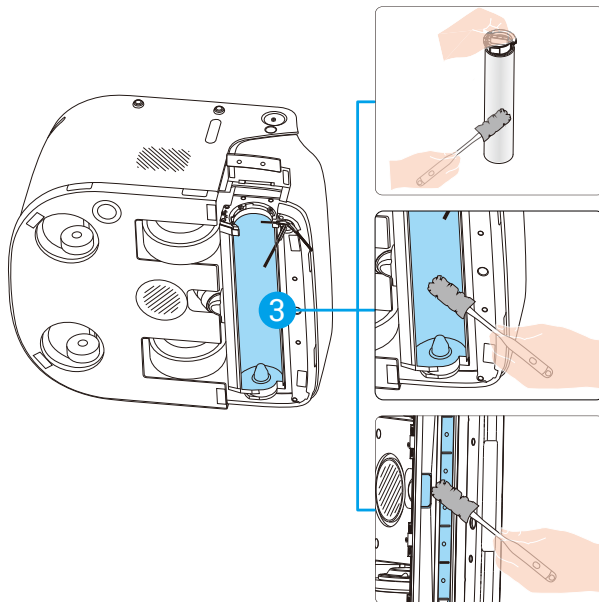

4. Put the main brush back in place (ensure the arrow on the brush aligns with the arrow on the robot), then rotate it clockwise. When the arrow on the brush aligns with the spring pin, it is properly installed.

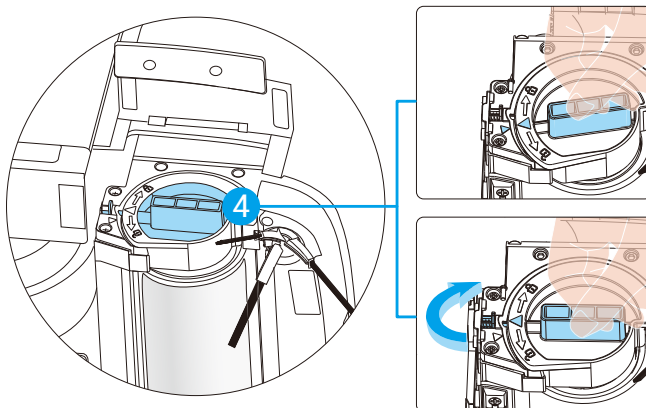

4. Clean Dirty Water Tank (Mopping version only)

1. Clean HEPA: Open the dirty water tank, remove HEPA and thoroughly clean it.

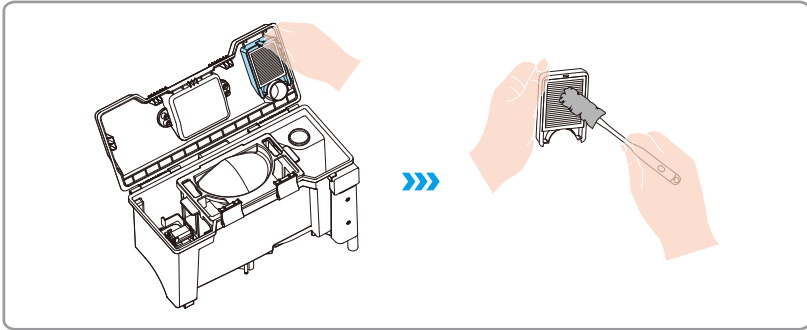

2. Clean the dustbin: Take out the dustbin and thoroughly clean it.

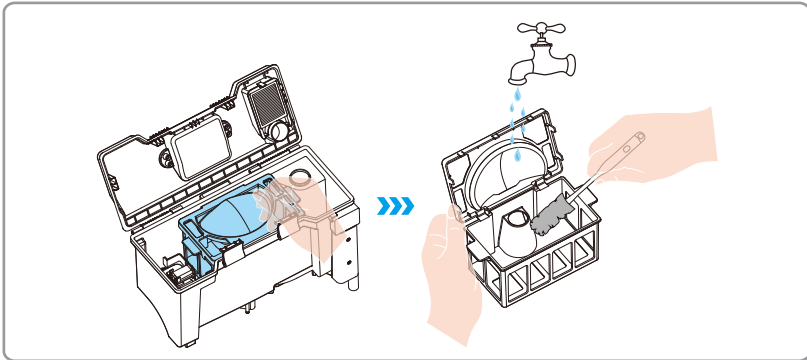

3. Clean the float assembly: Remove the float assembly and thoroughly clean it, especially the magnet on the float.

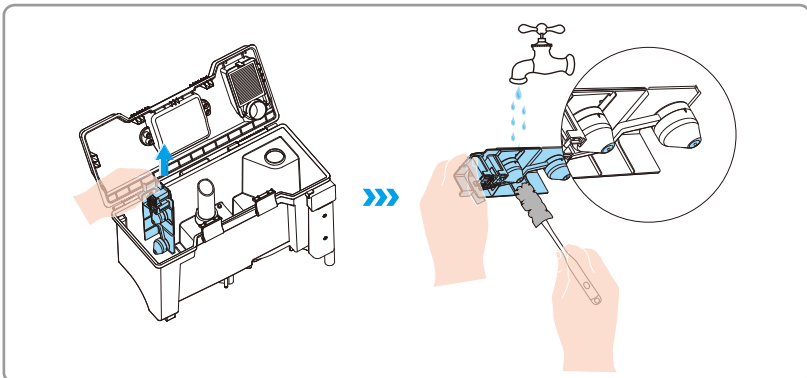

4. Clean the dirty water tank filter and drain port: Remove the filter from the dirty water tank, rinse it thoroughly with water, and clear the drain port with a cleaning tool.

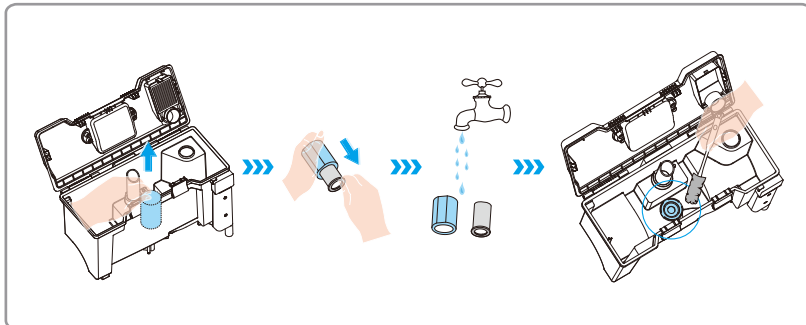

5. Reassemble all components: Put the HEPA, float assembly (with the float facing down), dirty water tank filter, and dustbin back into the dirty water tank.

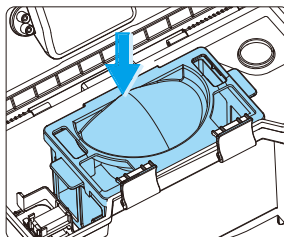
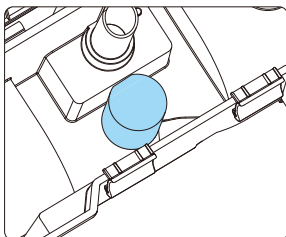
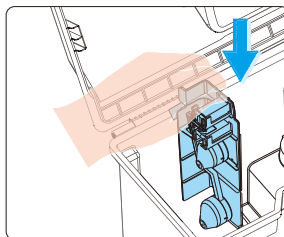
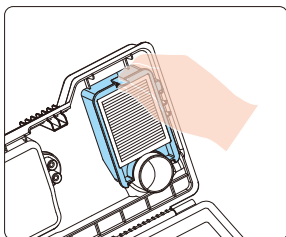

5. Clean Important Components

i Please use a soft, clean, dry cloth to clean the important components of the robot.

Clean **A** lens, **B** distance sensor, and **C** supplement light.

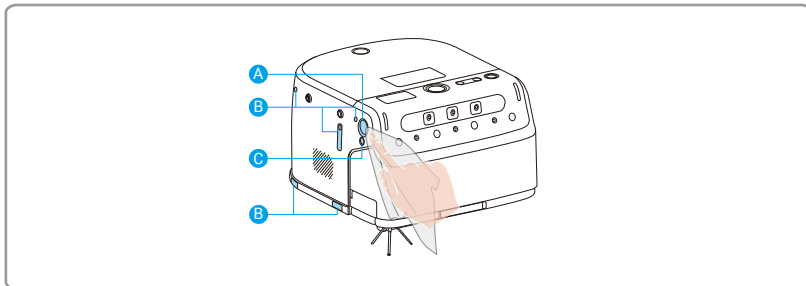

Clean **D** lens, **E** IR light, **F** distance sensor, and **G** vision modules.

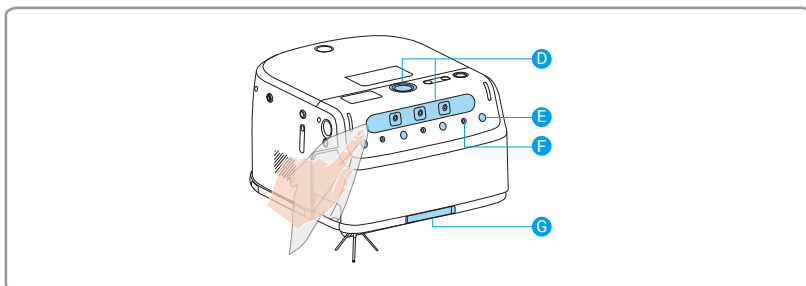

Clean **H** cliff sensor, **I** material sensor, and **J** optical flow sensor.

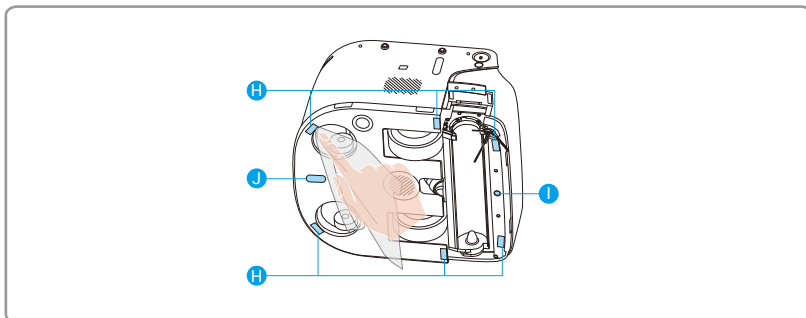

Clean **K** distance sensor, **L** charging sensor, and **M** charging contact.

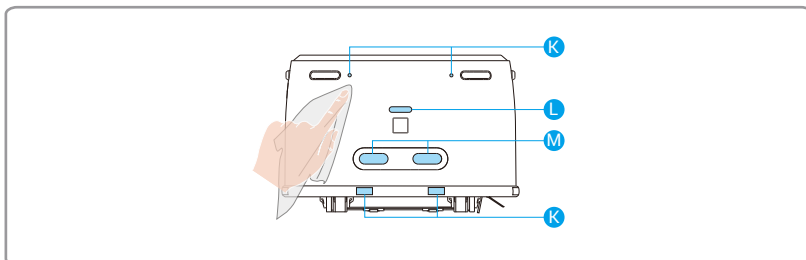

6. Replace Dust Bag (Vacuum version only)

i Please use a soft, clean, dry cloth to clean the important components of the robot.

1. Open the dust collection box latch, then pull and remove its cover as shown in the figure.
2. Lift the dust bag by its handle to remove it. Install a new dust bag, reinsert the dust collection box into the robot, and close the top cover.

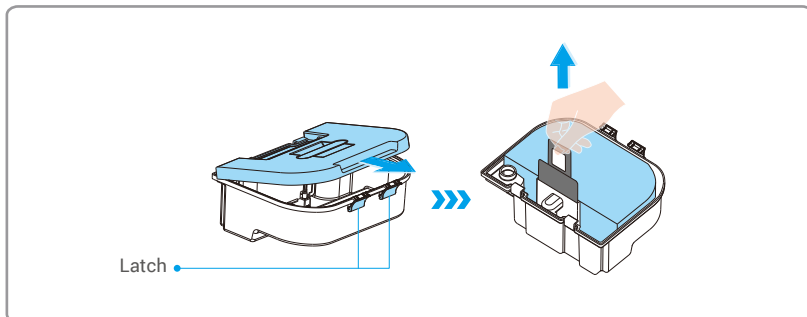

7. Recall Robot to Base Station

Mopping Version

Press  and the robot will return to the base station. If it fails, please follow the screen prompts to properly install components and retry.

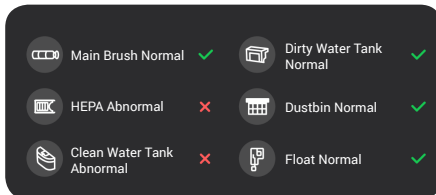

Vacuum Version

Press  and the robot will return to the base station.

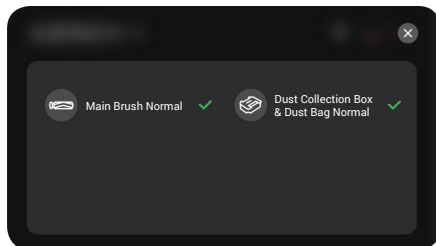

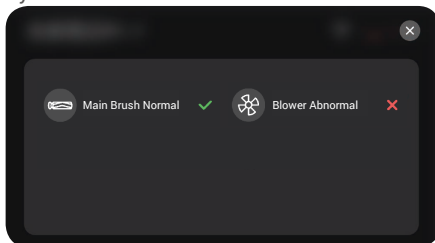

i The robot will enable self-checking before returning to the base station. If any components show ✗ on the screen, the robot will be unable to return to the base station. Please follow the screen prompts to properly install components and retry.

The base station will enable self-checking after robot returning. If any components show **X** on the screen, please follow the screen prompts to properly install components and retry.



- 1 • If the display screen indicates a blower abnormality, please check whether the dust bag is properly installed and whether the blower's air intake is blocked.
- If the issue persists, submit a service request via the "EZVIZ Robotics" client. The interface may be updated periodically, so refer to the actual screen for accurate details.

Problem	Solution
Charging failure	<ul style="list-style-type: none"> • Check whether the power cable of the base station is connected well. • Check whether the base station has been paired with the robot. • The base station and the robot are not aligned. Press the  button to retry.
Recharge failure	<ul style="list-style-type: none"> • Clean the obstacles in front of the base station. • Recommended place the robot back to the base station before each cleaning task and ensure the robot starts working from the base station. • Do not place the base station in direct sunlight. • Check if there is dirt on the charging contacts of the base station and the robot. If so, wipe them clean. • Network exception. Log in to the "EZVIZ Robotics" app, enter the device settings page, tap "Base Station Information -> Configure Base Station Network", and follow the instructions to connect the base station to the Wi-Fi network, then try again.
Abnormal obstacle avoidance	Use air blowing tool to clean the glass on the lens, or you can use soft tissues or dry pad to swipe the glass on the lens.
Abnormal noise during cleaning	<ul style="list-style-type: none"> • Foreign objects entangled to the wheels, side brushes or main brush, please start the robot after shutting down and clean it. • The rubber strip on dust collection inlet is scrapping the floor, which is a normal phenomenon.
LCD screen of the robot prompts "Base station pairing failed".	Press and hold the  to restart the base station, then restart the robot. If the connection still fails, delete the base station on the LCD screen and pair the base station with robot again.
Cannot connect to Wi-Fi	<ul style="list-style-type: none"> • Poor Wi-Fi signal, please ensure the robot is in a area with a good Wi-Fi signal. • Reconfigure the network.
Side brush fell off during cleaning	Turn the robot over and install the side brush again, make sure install it completely until hearing a "clip" sound.
Excessive water stains remain on the floor	<ul style="list-style-type: none"> • Remove the clean water tank and dirty water tank, place the robot on its side (do not invert it), and check if the rubber strip is blocked by foreign objects. • Abnormal suction port. Clean the main brush. • Check whether the "EZVIZ Robotics" app prompts that the main brush has reached the end of its service life or if the blower requires maintenance.
Base station prompts abnormal water filling	<ul style="list-style-type: none"> • Check if the float in the clean water tank is stuck. If so, gently shake the tank to free it. • Check if there is accumulated water in the robot's water inlet. If so, wipe it dry with a tissue.
Dirty water tank abnormal	Open the dirty water tank and check if the float is stuck by foreign objects.
Robot drainage abnormal	Clean the dirty water tank and replace the filter.
Base station repeatedly starts drainage	<ul style="list-style-type: none"> • Check if water is seeping from the inner wall of the base station. • Check if there is accumulated water inside the base station. If so, clean it.
Base station unable to drain	<ul style="list-style-type: none"> • Remove the stainless steel filter from the base station and clean the water reservoir pit with a brush. • Press the base station's  button to check if drainage returns to normal.

 For additional information about the robot, please refer to www.ezviz.com.

Environmental Precautions

The chemical substances contained in the built-in lithium-ion battery of this device may cause environmental pollution. Please remove it before scrapping and send it to a professional battery recycling station for centralized disposal.

Steps for removing the battery (the following information is only applicable when discarding the device, not the daily operation instructions):

1. Run the robot to a low battery status and unable to work, and during this period, do not allow it to return to the base station.
2. Turn off the robot and remove the side brush and mop bracket.
3. Turn the robot over and remove the screws at the bottom.
4. Remove the battery cover.
5. Take out the battery.

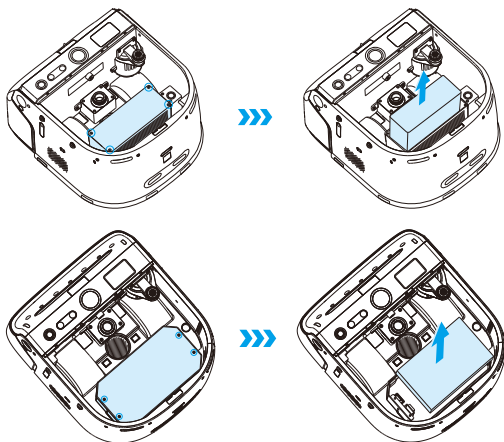

- When disassembling the battery, please ensure that the power is exhausted and operate with the base station disconnected.
- Please disassemble the whole battery pack together and do not damage the battery pack casing to avoid short circuit or leakage of hazardous substances.
- If the battery has exudate and accidentally touches it, please flush it with plenty of water and seek medical attention promptly.
- This product should not be discarded after the expiration date or after the repair cannot work normally, please hand it over to an enterprise qualified to dispose of WEEE, please refer to the national or local regulations on the disposal of WEEE for the correct method.

Initiatives on the Use of Video Products

Dear Valued EZVIZ Users,

Technology affects every aspect of our life. As a forward-looking tech company, we are increasingly aware of the role technology plays in improving efficiency and quality of our life. At the same time, we are also aware of the potential harm of its improper usage. For example, video products can record real, complete and clear images, therefore they hold great values in representing facts. Nevertheless, improper distribution, use and/or processing of video records may infringe on the privacy, legitimate rights and interests of others.

Committed to innovating technology for the good, we at EZVIZ hereby earnestly advocate that every user shall use video products properly and responsibly, thus to collectively create a positive environment where all related practices and usage comply with applicable laws and regulations, respect individuals' interests and rights, and promote social morality.

Here are EZVIZ's initiatives that we'd appreciate your attention:

1. Each individual possesses a reasonable expectation of privacy, and the use of video products should not be in conflict with such reasonable expectation. Therefore, a warning notice which clarifies the monitoring range should be displayed in a reasonable and effective manner, when installing video products in public areas. For non-public areas, the rights and interests of people involved shall be evaluated thoughtfully, including but not limited to, installing video products only after obtaining the consent of the stakeholders, and not installing highly-invisible video products without other's knowledge.
2. Video products objectively records footage of real activities within specific time and space. Users shall reasonably identify the people and rights involved in this scope in advance, to avoid any infringement of portrait, privacy or other legal rights of others while protecting themselves through video products. Notably, if you choose to enable the audio recording function on your camera, it will capture sounds, including conversations, within the monitoring range. We highly recommend a comprehensive assessment on the potential sound sources in the monitoring range, so as to fully understand the necessity and the reasonableness before you turn on the audio recording function.
3. Video products in use will consistently generate audio or visual data from real scenes –possibly including biometric information such as facial images – based on the user's selection of product features. Such data can be used or processed to use. Video products are only technological tools that do not and cannot humanly practice legal and moral standards to guide lawful and proper use of data. It is the methods and purposes of the people who control and use the generated data that make a difference. Therefore, data controllers shall not only strictly abide by applicable laws and regulations, but also fully respect non-obligatory rules including international conventions, moral standards, cultural norms, public order and local customs. Furthermore, we should always prioritize the protection of privacy and portrait rights, and other reasonable interests.
4. The video data continuously generated by video products carries the rights, values and other demands of various stakeholders. Thus, it is extremely crucial to ensure data security and shield the products from malicious intrusions. Every user and data controller shall, undertake all reasonable and necessary measures to maximize product and data security, avoiding data leakage, improper disclosure or misuse, including but not limited to, setting up access control, selecting a suitable network environment where video products are connected, establishing and constantly optimizing network security.
5. Video products have made great contributions to enhance the safety of our society, and we believe that they will continue to play a positive role in various aspects of our daily life. Any attempt to abuse these products to violate human rights or engage in unlawful activities contradicts the very essence of the value in tech innovation and product development. We encourage every user to establish your own methods and rules to evaluate and monitor the use of video products, so as to ensure that these products are always used properly, thoughtfully and with goodwill.